

SOLUTIONS FOR BUNDLING

PC2000 + PC2000P AUTOMATIC STRAPPING MACHINES

Greenbridge's PC2000 and PC2000P are world class, high-speed, fully automatic strapping machines. Both provide high reliability and performance, earning these machines the best price and value reputation in the market today.



**PC2000P is great
for graphic arts**



**Greenbridge has the
most extensive portfolio
of PET and PP strap and
cord in the industry.**

*Please contact us for a
recommendation.*



SUPER FAST!
Up to 65 Straps Per Minute

FEATURES

- Arch sizes up to 41"
- Standard arch size – 25"w x 19"h
- Robust, compact strapping head
- Direct cam drive: 30% fewer parts, no clutch or pulleys
- One piece strap chute
- Electronic brake
- Free access to strap guides
- Electronic tension control/auto strap ejector
- Hinged top plates (7 gauge)/ splashguard over seal head
- Multiple strap function for single, double, continuous strapping or transit mode
- Variable speed belt conveyor: 32 and 95 feet per minute
- Up + downstream interlock with complete plug connection
- Loop ejector

WHERE THE RUBBER MEETS THE ROAD.

PC2000 + PC2000S EQUIPMENT SPECS



SPECIFICATIONS

Cycle Rate	Up to 65 straps a minute based on arch + package size
Package Weight	Up to 100 lbs.
Strap Tension	Up to 115 lbs.
Polypropylene Strap	5mm, 6mm, 9mm, 12mm, 3/8", 1/2"
Electrical Requirements	110V 60Hz 1 Phase
Shipping Weight	450 lbs.

OPTIONS

- Dual photo eyes/Siemens PLC control
- Operator friendly low-strap sensor (triple lamp)
- Adjustable table height 31.5" to 35"
- Maximum tension of 115 lbs for 9mm strap
- Dual cylinder pneumatic press for agility + finely tuned package compression
- Energy saving transit with auto sleep mode

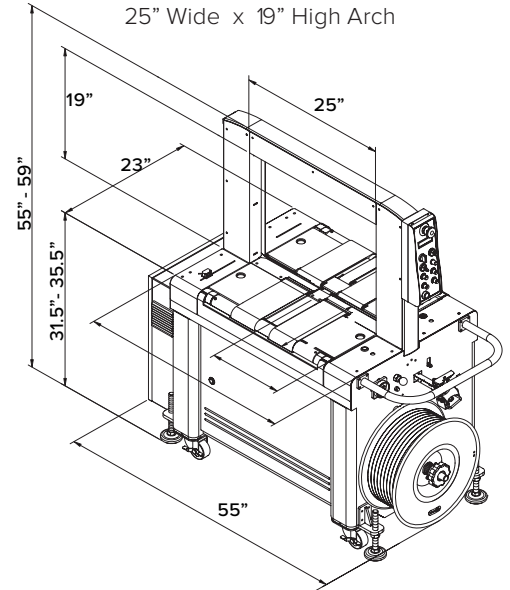

ABOUT GREENBRIDGE

Founded in 1974 as Polychem, we rebranded in April 2021 as Greenbridge to reflect our commitment to providing proactive solutions to customers across North America seeking to achieve more sustainable, high-performing operations. Our early reputation was based on our quality polyester, polypropylene and cord strapping. Today, years of growth and strategic acquisitions have made Greenbridge a leading end-of-line packaging supplier, with integrated solutions that encompass tools, equipment, systems, and services that help tame the most challenging supply chains.

Greenbridge is committed to the safety of our team, the quality of our products and services, investing in continuous improvement, advancing the circular economy, and fostering sustainable customer success.

It's easy to find a supplier to sell you equipment.

It's another thing to find one who understands your business.

Talk to Greenbridge.

G GREENBRIDGE

