



## SOLUTIONS FOR BUNDLING

### N3400C AUTOMATIC STRAPPING MACHINE

Introducing the N3400C arch machine – Your Ultimate Solution for Efficient Strapping! Enjoy uninterrupted performance with 55 cycles per minute, ensuring rapid and precise strapping for various applications, including boxes, lumber, and print media. The N3400C has been upgraded with a wear-free strap frame featuring stainless steel guides and an operation terminal equipped with soft buttons, making it intuitive and easy to operate. Bid farewell to manual hassles as the automatic start feature streamlines your strapping process. This innovative solution ensures not only hassle-free operation but also durability, making the N3400C the go-to choice for efficient and reliable strapping applications. Moreover, the N3400C requires less maintenance with its brushless direct drive motors, providing a cost-effective and user-friendly strapping solution.

**ENERGY SAVING MOTORS!**

### The N3400C is Ideal for



### FEATURES

- Up to 55 cycles per minute, depending on tension settings and package size
- Automatic strap feed
- Automatic cycle start by tabletop sensor
- Wear-free, Energy Saving 24VDC direct-drive motors
- Strap width 5-12 mm
- Footbar at operator side  
Adjustable torque controlled strap tension
- Wear-free strap frame with stainless steel guides
- Strap end detection system with automatic discharge of remaining strap
- MFT 'Mono-Frame-Technology'
- ASLF 'Anti-Strap-Loss-Function' constant strap control
- External dispenser
- Power connection at the top of the arch or bottom of the machine
- Power Switch with lockout
- Exclusive eject function avoids strap jam
- Operation terminal with soft button
- Hinged removable tabletops



# INNOVATIVE, RELIABLE, ENERGY-SAVING

## N3400C EQUIPMENT SPECS

### SPECIFICATIONS

<b>Cycle Rate</b>	Up to 55 cycles per minute
<b>Cycle Initiation</b>	Photo eye sensor or footbar
<b>Package Weight</b>	386 lbs. (175kg)**
<b>Package Size</b>	Min. 1.37" H x 2.5" W (Max. Governed by Arch)
<b>Strap Tension</b>	Adjustable Electronic Control
<b>Strap Size</b>	1/4" - 1/2" (5mm-12mm)
<b>Standard Arch Size</b>	23" x 23"
<b>Seal Head Location</b>	Bottom
<b>Sealing Method</b>	Heat Seal
<b>Mobility</b>	3" Casters
<b>Dispenser</b>	Externally Located 8" or 9" I.D./ 8" Face/ 18" O.D.
<b>Power</b>	110V Single Phase

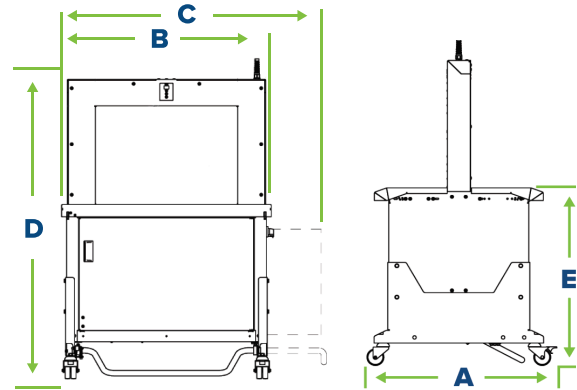

#### Options:

AUTOMATIC ULTRASONIC STRAP TENSIONING  
EXTERNAL DISPENSER

All Metal Strap Drive Rollers

DAT (Direct Access Technology)

HOT Knife Sealing Technology

Fewer Moving Wear Parts

#### Additional Models Available:



**N3400CM**



**N3400CB**

#### Overall Width: (A)

32.5"  
(828mm)

#### Overall Length: (B)

37.6"  
(956mm)\*

#### Overall Length: (C) (with external dispenser)

47.6"  
(1210mm)\*

#### Overall Height: (D)

61.6 - 66.3"  
(1565 - 1685mm)\*

#### Table Height:

31.3 - 35.8"  
(795 - 910mm)

### ABOUT GREENBRIDGE

Founded in 1974 as Polychem, we rebranded in April 2021 as Greenbridge to reflect our commitment to providing proactive solutions to customers across North America seeking to achieve more sustainable, high-performing operations. Our early reputation was based on our quality polyester, polypropylene and cord strapping. Today, years of growth and strategic acquisitions have made Greenbridge a leading end-of-line packaging supplier, with integrated solutions that encompass tools, equipment, systems, and services that help tame the most challenging supply chains.

*Greenbridge is committed to the safety of our team, the quality of our products and services, investing in continuous improvement, advancing the circular economy, and fostering sustainable customer success.*

**It's easy to find a supplier to sell you equipment.**

**It's another thing to find one who understands your business.**

**Talk to Greenbridge.**

**GREENBRIDGE**  
YOUR BRIDGE TO **BUNDLED**

WWW.GREENBRIDGE.COM | 800-548-9557 | HELLO@GREENBRIDGE.COM