

SOLUTIONS FOR BUNDLING

N3400RA AUTOMATIC STRAPPING MACHINE

Introducing the N3400RA arch machine – Your Ultimate Solution for Efficient Strapping! Enjoy uninterrupted performance with 20 cycles per minute, ensuring rapid and precise strapping for various applications, including boxes, lumber, and print media. The N3400RA has been upgraded with a wear-free strap frame featuring stainless steel guides and a retractable arch, making it intuitive and easy to operate. Bid farewell to manual hassles as the automatic start feature streamlines your strapping process. This innovative solution ensures not only hassle-free operation but also durability, making the N3400RA the go-to choice for efficient and reliable strapping applications. Moreover, the N3400RA requires less maintenance with its brushless direct drive motors, providing a cost-effective and user-friendly strapping solution.

Attributes of the N3400RA

-  **Powerful**
-  **Variable Strap Width**
-  **Pneumatic Free**
-  **Economical**
-  **Low Maintenance**

ENERGY SAVING MOTORS!



FEATURES

- | | | |
|--|---|--|
| <ul style="list-style-type: none"> ■ Up to 20 cycles per minute, depending on tension settings and package size ■ Wear-free, Energy Saving direct-drive motors ■ Strap end detection system with automatic discharge of remaining strap ■ ASLF 'Anti-Strap-Loss-Function' constant strap control | <ul style="list-style-type: none"> ■ DAT 'Direct Access Technology' ■ Automatic strap feed ■ Low maintenance and low wear strap arch ■ GreenTech energy concept ■ Coil outside | <ul style="list-style-type: none"> ■ Torque controlled strap tension ■ SAN - Small and Narrow ■ Retractable arch ■ Strap Width 5mm - 12mm ■ Low power consumption |
|--|---|--|

INNOVATIVE, RELIABLE, ENERGY-SAVING N3400RA EQUIPMENT SPECS

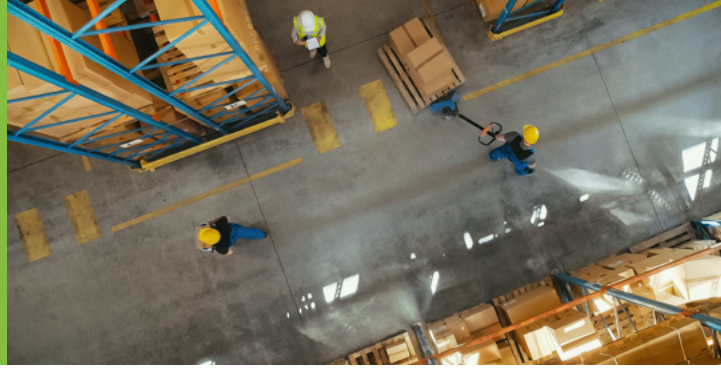

SPECIFICATIONS

Cycle Rate	Up to 20 cycles per minute
Cycle Initiation	Photo eye sensor
Package Weight	386lbs
Package Size	Min. 5mm H x 40mm W (Max. Governed by Arch)
Strap Tension	Adjustable with 10 Steps
Strap Size	5mm-12mm
Standard Arch Size	11" x 7"
Seal Head Location	Bottom
Sealing Method	Heat Seal
Dispenser	Externally Located
Power	8" x 8" / 9" x 8" Wide Range Input 100-240V, 1AC: 47-63 Hz

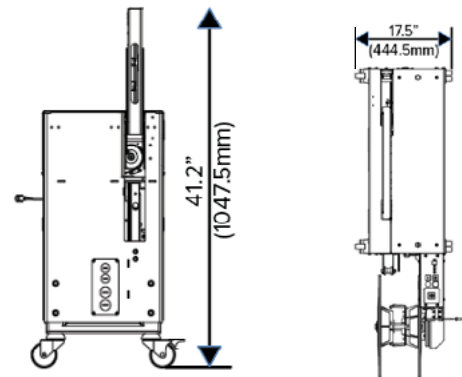
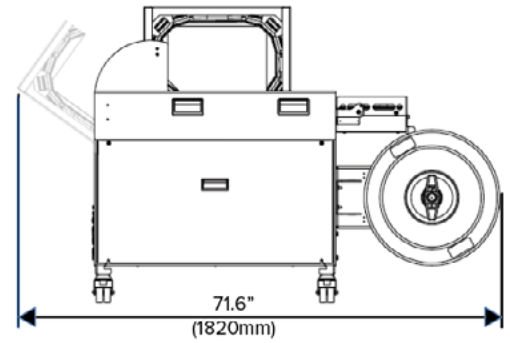

OPTIONS:

N3400SA // N3400SCA



ABOUT GREENBRIDGE

Founded in 1974 as Polychem, we rebranded in April 2021 as Greenbridge to reflect our commitment to providing proactive solutions to customers across North America seeking to achieve more sustainable, high-performing operations. Our early reputation was based on our quality polyester, polypropylene and cord strapping. Today, years of growth and strategic acquisitions have made Greenbridge a leading end-of-line packaging supplier, with integrated solutions that encompass tools, equipment, systems, and services that help tame the most challenging supply chains.

Greenbridge is committed to the safety of our team, the quality of our products and services, investing in continuous improvement, advancing the circular economy, and fostering sustainable customer success.

It's easy to find a supplier to sell you equipment.

It's another thing to find one who understands your business.

Talk to Greenbridge.

GREENBRIDGE
YOUR BRIDGE TO BUNDLED