

## SOLUTIONS FOR BUNDLING





### NP7000 NEWSPAPER STRAPPING MACHINE

Introducing the NP7000 Arch Strapping Machine, a game-changer in the world of bundling efficiency. Powered by Direct Drive Servo Motors, this machine guarantees precise control and minimal maintenance with its streamlined design. Boasting simplicity in operation, the NP7000 stands out with its Smart Touch Control Panel, facilitating easy setup and user-friendly navigation. The minimalist approach to parts enhances reliability and troubleshooting, ensuring a seamless strapping process. With a remarkable strapping speed of up to 45 bundles per minute, this machine is a powerhouse of productivity, accommodating high-volume production with ease. The NP7000 is not just a strapping machine; it's a smart investment in efficiency, precision, and user-friendly operation for your packaging needs.

**HIGH SPEED!**



### The NP7000 Capabilities



-  Conveyor Speed Control
-  Conveyor Height Adjustable
-  Bundle Conditioning System
-  Auto-Adjust Strap Tension
-  Operational Light Tower

### FEATURES



#### New Strap Sealing Head

-  Direct Drive Servo Motors  
Control and simplicity with minimal parts.
-  DAT - Direct Access Technology  
Easy access to strap path for cleaning and clearing strap.

#### Increased Uptime

-  Jam Free Strap Eject Function  
Provides ease in setup and operation.
-  XL Coil Capacity  
Accepts XL and standard strap coils, XL coils offer cost saving with longer footage.

#### Operator-Friendly Design

-  Smart Touch Control Panel  
Provides ease in setup and operation.
-  Safety Interlocks  
Safe and open conveyor interlocks disable machine operation when conveyors open.

# INNOVATIVE, RELIABLE, ENERGY-SAVING NP7000 EQUIPMENT SPECS

## SPECIFICATIONS

<b>Capacity</b>	Up to 45 bundles per minute
<b>Conveyor Speed</b>	Adj. up to 197ft/min (60 m/min)
<b>Strap Tension</b>	Max. 73.0 lbs. (325 N)
<b>Sealing Method</b>	Heat Seal
<b>Strap Coil</b>	8 x 8
<b>Power Supply</b>	120V - 480V
<b>Power Consumption</b>	0.35 kW
<b>Weight</b>	836 lbs. (380 Kg)
<b>Bundles</b>	Max Height 15.7" (400mm) Max Weight 55.1 lbs. (25Kg.)
<b>Strapping Material</b>	Polypropylene Width: 1/4"-1/2" (5-12mm) Thickness: .016"-.022" (0.4-0.55mm)

**Additional Options: Pro and Plus  
Models Available**

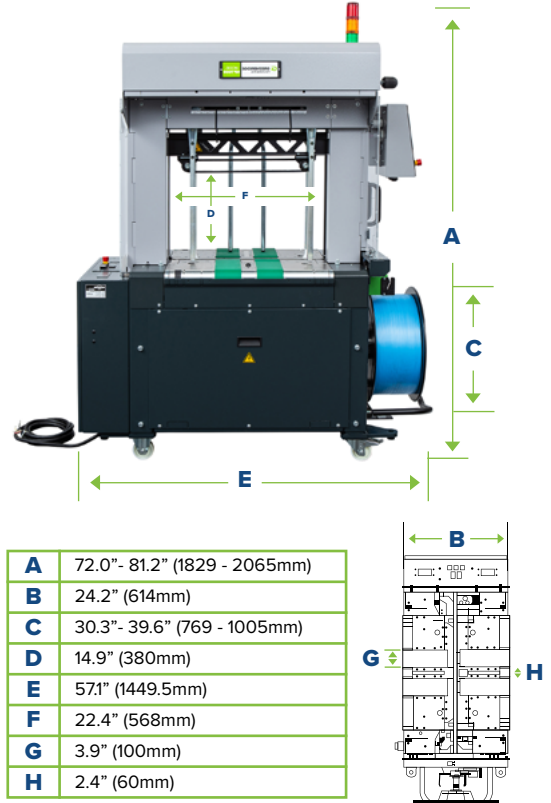

<b>A</b>	72.0" - 81.2" (1829 - 2065mm)
<b>B</b>	24.2" (614mm)
<b>C</b>	30.3" - 39.6" (769 - 1005mm)
<b>D</b>	14.9" (380mm)
<b>E</b>	57.1" (1449.5mm)
<b>F</b>	22.4" (568mm)
<b>G</b>	3.9" (100mm)
<b>H</b>	2.4" (60mm)

## ABOUT GREENBRIDGE

Founded in 1974 as Polychem, we rebranded in April 2021 as Greenbridge to reflect our commitment to providing proactive solutions to customers across North America seeking to achieve more sustainable, high-performing operations. Our early reputation was based on our quality polyester, polypropylene and cord strapping. Today, years of growth and strategic acquisitions have made Greenbridge a leading end-of-line packaging supplier, with integrated solutions that encompass tools, equipment, systems, and services that help tame the most challenging supply chains.

*Greenbridge is committed to the safety of our team, the quality of our products and services, investing in continuous improvement, advancing the circular economy, and fostering sustainable customer success.*

**It's easy to find a supplier to sell you equipment.**

**It's another thing to find one who understands your business.**

**Talk to Greenbridge.**

**GREENBRIDGE**  
YOUR BRIDGE TO BUNDLED